

N 70, Integrated Design Hood, 90 cm, clear glass white  
printed  
D94XAF8NOB



COOKING PASSION SINCE 1877



B

Our invisible integrated design hood - perfectly integrated with extra storage for easy access items, such as spices and herbs.

✓ LED Lighting - Clear illumination while you cook.

#### Features

##### Technical Data

Typology : Built-in/Built-under  
Approval certificates : CE  
Length of electrical supply cord : 150 cm  
Required niche size for installation (HxWxD) : 356mm x 862.0mm x 310mm mm  
Height of product, without chimney : 60 mm  
Minimum distance above an electric hob : 500 mm  
Minimum distance above a gas hob : 650 mm  
Net weight : 14.050 kg  
Type of control : mechanical  
Number of speed settings : 3  
Maximum output air extraction : 610 m<sup>3</sup>/h  
Maximum output recirculating air : 585 m<sup>3</sup>/h  
Number of lights (Stck) : 2  
Noise level : 70 dB(A) re 1 pW  
Diameter of air outlet : 150 mm  
Grease filter material : Washable aluminium  
EAN code : 4242004243632  
Connection rating : 255 W  
Voltage : 220-240 V  
Frequency : 50; 60 Hz

#### Optional accessories

Z51IBG0N1	Chimney extension 120mm
Z51IBN0N0	Chimney extension 187-360mm
Z51IBU0X0	Standard recirculation kit
Z51IMA0X0	Standard odor filter (replacement)
Z51ITD1X1	Long Life recirculation kit external
Z51IXB1X6	Clean Air Plus odor filter (replacement)
Z51IXC1X6	Clean Air Plus recirc. kit external



4 242004 243632

N 70, Integrated Design Hood, 90 cm, clear glass  
white printed  
D94XAF8NOB



COOKING PASSION SINCE 1877

## Features

### Key performance features:

- Energy Efficiency Class: B (at a range of energy efficiency classes from A+++ to D)
- Extraction rate according to EN 61591 max. 610 m<sup>3</sup>/h
- Noise max. Normal Level: Noise, max. speed in normal us: 70 dB dB\*

### Features

- 3 power levels via rotary switch, retractable
- White with LED backlit glass panel
- 2 x LED 2.5W
- Colour Temperature: 3500 K
- Filter cover glass, metal grease filter
- 2 metal grease filter cassettes
- Installation: Cupboard 90 cm

### Design

- Adjustable glass visor for additional vapour capture
- Filler strip for an individual depth adjustment in cupboard up to maximum 350 mm.
- Mechanical controls

### Performance/technical information

- Suitable for ducted extraction and recirculation
- For recirculated extraction recirculating kit or CleanAir recirculating kit (accessory) needed
- Max. extraction rate: 610 m<sup>3</sup>/h
- Noise level according to EN 60704-3 and EN 60704-2-13 at max. normal use exhaust air: 70 dB(A) re 1 pW
- Power rating: 255 W
- Light Intensity: 76 lux
- Electrical cable length 1.5 m
- Diameter pipe Ø 150 mm (Ø 150 mm enclosed)
- Dimensions (HxWxD): 356 x 894 x 310 mm
- Built-in dimensions (HxWxD): 356 x 862 x 310-350 mm
- Blower Efficiency Class: B\*
- Lighting Efficiency Class: A\*
- Grease Filtering Efficiency Class: C\*
- Average Energy Consumption: 61 kWh/year\*

### Optional accessories

- Recirculating kit Z51IBG0N1

\* In accordance with the EU-Regulation No 65/2014

N 70, Integrated Design Hood, 90 cm, clear glass  
 white printed  
 D94XAF8NOB

## Dimensioned drawings

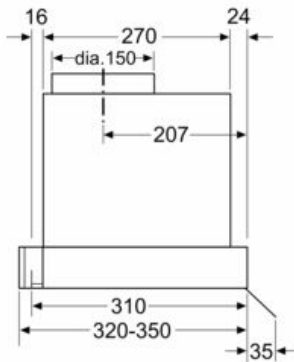
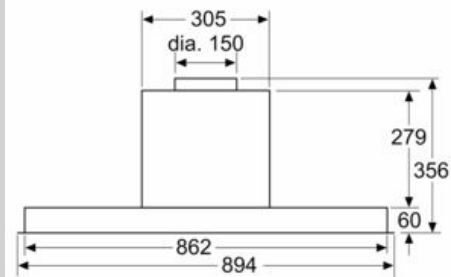
 measurements in mm  
 side view

 measurements in mm  
 front view

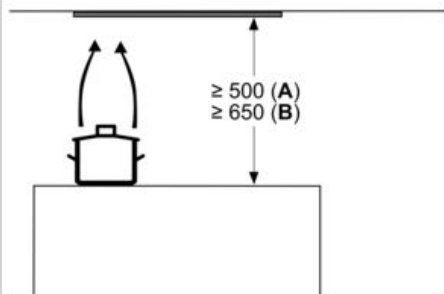
measurements in mm

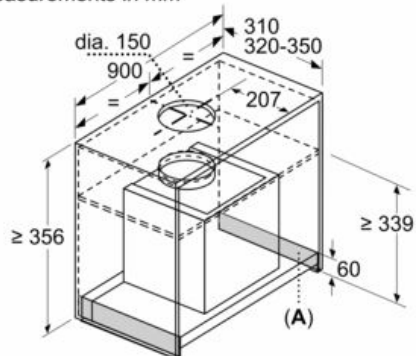

From upper edge of pan support:  
**A:** Electric  
**B:** Gas

measurements in mm



A: Area without hinge