

N 70, Built-in vacuum drawer, 60 x 14 cm, Stainless steel
N17XH10N0



COOKING PASSION SINCE 1877



NEFF vacuum drawer – the flexible vacuum sealer adds a whole new layer of flavours and opportunities to your kitchen equipment

- ✓ Sous-vide – the NEFF chamber system is tailor-made to vacuum-seal Sous-vide recipes since intensified flavours highlight your finest ingredients and high-quality meat
- ✓ External vacuum-sealing – your handy extension for flexible sealing of larger jars and plastic containers

Features

Technical Data

Net weight : 31.655 kg

Gross weight : 34.2 kg

Product image :

MCSA01787170_G7478_N17XH10N0_1218331_def.jpg

EAN code : 4242004216643

Dimensions of the packed product (HxWxD) : 230 x 660 x 660 mm



4 242004 216643

Optional accessories

Z11SZ60X0 SeamlessCombination 45 + 14cm

*N 70, Built-in vacuum drawer, 60 x 14 cm,
Stainless steel
N17XH10N0*

Features

Design

- Touch Control illuminated
- Push-Pull opening mechanism
- Touch key operation
- Automatic connection recognition for vacuuming outside the chamber

Programmes/functions

- 3 vacuuming levels for vacuuming in the chamber, max. 99%
- 3 vacuuming levels for vacuuming outside the chamber, max. 90%
- Drying program for vacuuming pump

Technical information

- Power cord length 150 cm Cable length
- Cavity Volume: 8 l
- Total connected load electric: 0.32 KW
- Nominal voltage: 220 - 240 V
- Appliance dimension (hxwxd): 140 mm x 595 mm x 542 mm
- Niche dimension (hxwxd): 141 mm x 560 mm - 568 mm x 550 mm
- Please refer to the dimensions provided in the installation manual

N 70, Built-in vacuum drawer, 60 x 14 cm,
 Stainless steel
 N17XH10N0

Dimensioned drawings

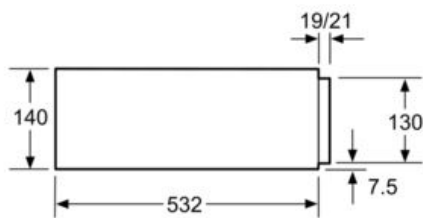

Compact ovens with an appliance height of 455 mm can be installed above a warming drawer. An intermediate floor is not required.

measurements in mm

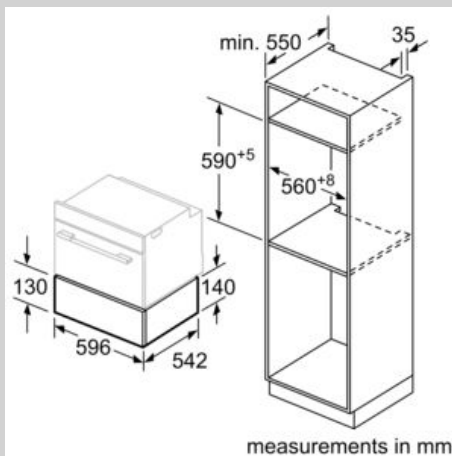

measurements in mm