

N 90, Induction hob with integrated ventilation system, 80 cm
T58TL6EN2

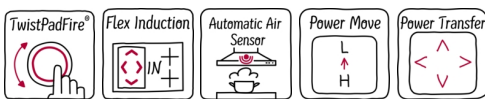

B



This induction hob with integrated ventilation combines two appliances in one for a clear view while cooking.

- ✓ TwistPadFire® – our removable, magnetic, illuminated control dial that gives you precise control over all cooking zones.
- ✓ Flex Induction – Your hob detects and heats your individual cookware.
- ✓ Automatic Air Sensor – Constantly adjusts the extraction rate to match the situation in the kitchen.
- ✓ Power Move – Just slide your cookware to adjust the temperature.
- ✓ Power Transfer – when you reposition a pot, your settings automatically follow the cookware.

Features

Technical Data

Product name/family : Cooking zone ceramic
 Construction type : Built-in
 Energy input : Electric
 Required niche size for installation (HxWxD) : 223 x 750-750 x 490-490 mm
 Width of the appliance : 826 mm
 Dimensions : 223 x 826 x 546 mm
 Dimensions of the packed product (HxWxD) : 430 x 956 x 670 mm
 Net weight : 28.615 kg
 Gross weight : 33.5 kg
 Residual heat indicator : Separate
 Location of control panel : Hob front
 Basic surface material : Ceramic
 Color of surface : Black, Stainless steel
 Color of frame : Stainless steel
 Approval certificates : CE, VDE
 Length of electrical supply cord : 110 cm
 Knob Material : Plastic
 Sealed Burners : No
 heating with booster : All
 Power of 2nd heating element (kW) : 3.3 kW
 : 3.7 kW
 Maximum output air extraction : 500 m³/h
 Boost position output recirculating : 615.0 m³/h
 Maximum output recirculating air : 500 m³/h
 Boost position air extraction : 622 m³/h
 Noise level : 69 dB(A) re 1 pW
 Odour filter : No
 Operating Mode : Convertible
 Delay Shut off modes : 30 min
 Electrical connection rating : 7400 W
 Voltage : 220-240/380-415 V
 Frequency : 50-60 Hz
 Main colour of product : Black
 Approval certificates : CE, VDE
 Length of electrical supply cord : 110 cm
 Required niche size for installation (HxWxD) : 223 x 750-750 x 490-490 mm
 Dimensions : 223 x 826 x 546 mm
 Dimensions of the packed product (HxWxD) : 430 x 956 x 670 mm
 Net weight : 28.615 kg
 Gross weight : 33.5 kg

Optional accessories

Z811DU0 : Acoustics Filter , Z821PD0 : Basic kit (partly-)ducted recirculation , Z821PD1 : Plinth Diffusor , Z821UD0 : Kit Unducted Recirculation , Z821VR0 : cleanAir recirculation replenishment fil , Z861KE1 : Exhaust kit , Z861KR0 : Recirculation kit 2 L-bow (70cm) , Z861KR1 : Recirculation kit S and L-bow (60cm) , Z861SB1 : 90° flat duct bend horizontal , Z861SB2 : 90° flat duct L vertical , Z861SB3 : 90° flat duct M vertical , Z861SB4 : 90° flat duct S vertical , Z861SI0 : Adapter round-flat , Z861SI1 : 90° Adapter round-flat , Z861SM1 : Straight tube 500mm , Z861SM2 : Straight tube 1000mm , Z861SS1 : Connector sleeve (female) , Z861SS2 : Flex sleeve (female) , Z9410X1 : Stainless Steel roaster with glas lid , Z9415X1 : Steaming Rack for Stainless Steel roaste , Z9416X2 : Griddle Plate , Z9417X2 : Teppan Yaki (large) , Z943SE0 : Set of 2 pots and 1 pan , Z9914X0 : Connecting strip



*N 90, Induction hob with integrated ventilation
system, 80 cm
T58TL6EN2*

Features

Design

- Ceramic glass on stainless steel trim
- 80 cm: space for 4 pots or pans.

Flexibility of cooking zones

- 2 Flex zones: use cookware of any shape or size anywhere within the 40cm long zone.
- Cooking zone front left: 200 mm, 240 mm, 2.2 KW (max. power 3.7 KW)
- Cooking zone rear left: 200 mm, 240 mm, 2.2 KW (max. power 3.7 KW)
- Cooking zone rear right: 200 mm, 240 mm , 2.2 KW (max power 3.7 KW)
- Cooking zone front right: 200 mm, 240 mm, 2.2 KW (max. power 3.7 KW)

Usage convenience

- TwistPad® Fire: directly control the power with the illuminated and removable magnetic dial.
- Variable 17-stage power settings for each zone: precisely adapt the heat with 17 power levels (9 main levels and 8 intermediate levels).
- Keep warm function: keep dishes warm at preset low power level.
- Timer with automatic shut off for all zones : switches off the cooking zone at the end of the time set (e.g. for boiled eggs).
- LED timer for each zone with switch off function and acoustic signal : an alarm sounds at the end of the time set (e.g. for pasta).
- Count up timer : shows how much time has passed since starting the timer (e.g. for potatoes).

Time saving & efficiency

- Power Boost function for all zones : boil water faster thanks to 50% more energy than at the highest standard level.
- PanBoost: heat up pans faster than at the highest standard level while protecting the pan coating.
- Cooking zones will be automatically joined or separated based on the shape and size of the cookware placed.
- PowerMove with 3 levels: increase or decrease the power level simply by moving the pot forwards or backwards.
- PowerTransfer: when moving a pot to a different cooking zone, this feature transfers all previous settings to the new zone at the touch of a button.
- QuickStart function: when switching on, the hob automatically selects the cooking zone with cookware (when placed on a zone whilst the hob is off).
- ReStart function: in case of unintentional switch-off, this feature restores all previous settings by switching on the hob again within 4 seconds.

Cooking assistance

- 5 frying levels: prevents overcooking with the automatic temperature regulation of the integrated sensor.
- Dish assistant: easily find the right temperature setting for a certain dish via the home connect app.

Connectivity

- Home Connect with Remote Monitoring: check if the hob is switched off even when not at home, and find recipes or additional functions in the Home Connect app.

Safety

- 2 stage residual heat indicators: indicates which cooking zones are still hot or warm.
- Control panel lock: prevent unintended activation of the hob.
- Control panel suspension: wipe overboiled liquids without unintentionally changing settings (blocking all touch buttons for 30 seconds).
- Main switch: switch off all cooking zones at the touch of a button.
- Safety cut out facility: for safety reasons, heating stops after a preset time if not used (possible to customise).
- Energy consumption display: shows the electricity consumption of the last cooking process.

Installation

- Dimensions of the product (HxWxD mm): 223 x 826 x 546
- Required niche size for installation (HxWxD mm) : 223 x 750 x (490 - 490)
- Min. worktop thickness: 16 mm
- Connected load: 7.4 KW
- 4.6kW power output (20A); current management options for 16A, 13A or 10A connection: limit the maximum power if needed (depends on fuse protection of electric installation).
- Power cord: 1.1 m, Cable included in packaging

Accessories

- adjustment strip 750 - 780 mm included

Integrated ventilation downdraft system

- Induction cooktop with fully integrated high-performance downdraft extractor.
- Suitable for ducted or recirculated extraction configuration (incl. differentiated software modes). Installation accessories for unducted recirculation, among these four cleanAir odor filters and a telescopic slider element, are included in the cooktop. Accessories for other installation options are available, details in the planning notes.
- Aesthetically integrated fully flush air intake design with floating, heat resistant glass ceramics element for free movement and placement of cookware.
- Ventilation system with 17 electronically controlled fan power levels and 2 Boost-/Intensive fan power levels (with automatic

*N 90, Induction hob with integrated ventilation
system, 80 cm
T58TL6EN2*



COOKING PASSION SINCE 1877

Features

- revert) via TwistPad® Fire user interface. Sensor-based, smart, fully automatic mode of ventilation system:
- - Automatic switch-on of ventilation system when a cooking zone is used.
 - - Sensor-based and cooktop-based, fully-automatic adjustment of power levels via advanced algorithm for maximum convenience.
 - - 3 possible sensitivity modes of algorithm for maximum convenience (Low-noise oriented, balanced, performance-oriented).
 - - Automatic delayed shut-off after cooking to erase residual odors after cooking (in specific ultra low-noise fan level, 12min in ducted extraction, 30min in recirculated extraction, can be shut-off manually).
 - - Manual control possible via TwistPad® Fire.
 - High-performance, low-noise blower with energy-efficient BLDC-technology. High extraction rates at very low noises with pleasant noise frequencies through psycho-acoustically and aerodynamically optimized interior with enclosed, non-visible blower. Highly pressuredrop resistant even with longer and more complex ductings.
 - Easy-to-detach and easy-to-clean grease filter and liquid collector unit:
 - Convenient one-hand removal of unit via floating glass ceramics handle.
 - - Integrated, large-scale, high performance stainless-steel grease filters with 12 filtration layers and one black top layer for enhanced aesthetical integration. Grease filtration efficiency of 94 %.
 - - All parts of the unit are easy-to-clean, fully dishwasher safe and heat resistant.
 - - (Upper) Liquid collector unit with 200ml of capacity for standard accidental spillages or cooking condensate.
 - - Powerful drainage system for spillages that exceed 200ml of liquids.
 - - Liquid safety collector with additional capacity of 700ml for more severe accidental situations. Dishwasher safe. Easily accessible and detachable from below.
 - - Overall capturing capacity of 900ml (200ml + 700ml).
 - - Watertight blower system.
 - Ventilation system performance:
 - - Extraction performance in ducted extraction (according to EN 61591): min. normal setting 154 m³/h , max. normal setting 500 m³/h , max. Boost-/Intensive setting 622 m³/h .
 - - Extraction performance in recirculated extraction (according to EN 61591): min. normal setting 150 m³/h , max. normal setting 500 m³/h , max. Boost-/Intensive setting 615 m³/h.
 - - Noise level in ducted extraction (Sound power level according to EN 60704-3): min. normal setting 42 dB re 1 pW, max. normal setting 69 dB re 1 pW, max. Boost-/Intensive setting 74 dB re 1 pW.
 - - Noise level in recirculated extraction (Sound power level according to EN 60704-3.): min. normal setting 41 dB re 1 pW, max. normal setting 68 dB re 1 pW, max. Boost-/Intensive setting 72 dB re 1 pW.
 - - Grease filter efficiency (according to EN 61591) 94 %.
 - Consumption data and energy efficiency (according to Regulation (EU) No 65/2014):
 - - Energy Efficiency Class: B (at a range of energy efficiency classes from A+++ to D).
 - - Fluid Dynamic Efficiency: A .
 - - Average energy consumption: 57 .
 - - Grease filtration efficiency class: B .
 - - Noise min. normal setting & max. normal setting: 42 dB & 69 dB .
 - For recirculation configuration: 2 x 2 battery of directly integrated, high-performance cleanAir odor filters.
 - - Optimised odour reduction performance for cooking applications with complex odour molecules (e.g. fish).
 - - Large scale filter surface with high odour reduction capabilities.
 - - Lifetime of 360 hours of cooking (non-regenerative).
 - - Low-noise filters with optimised psycho-acoustics.
 - - Easy-to-access and easy-to-remove from above.
 - - Saturation indications for cleanAir odour filter via user interface notification and via the Home Connect app with a convenient replenishment re-order option (replenishment cleanAir filter set Z821VR0).
 - For ducted extraction configuration: 2 x 2 sets of directly integrated, high-performance low-noise acoustic filters for significantly lower noise and improved psycho-acoustics.

Planning & installation notes

- Suitable for ducted or recirculated extraction configuration in 4 different options (unducted, partly and fully ducted recirculation or ducted extraction). Installation accessories for unducted recirculation, among these four cleanAir odor filters and a telescopic slider element, are included in the cooktop. The included accessories allow easy and quick installations and can be planned in all worktop depths ≥60cm. For other types of installation, one of the following accessory kits is recommended:
 - Z861KE1 as starter kit for ducted extraction in worktops of ≥60cm depth.
 - Z861KR1 for partly-ducted recirculation in worktops of ≥60cm depth with max. worktop height of 960 mm. Z861KR0 for partly-

*N 90, Induction hob with integrated ventilation
system, 80 cm
T58TL6EN2*

Features

- ducted recirculation in worktops of 70cm depth of ≥ 70 cm depth with max. worktop height of 960 mm.
- To complete the fully ducted extraction or to do any other individual recirculation planning different ducting accessories are available.
 - Planning suggestions:
 - - Installation is possible in island as well as wall oriented configurations.
 - The product and its accessories comply with the Needle Flame Test (according to IEC 60695-11-5) and the V2 flammability class (according to UL94).
 - - The max. immersion depth is 223 mm below worktop surface.
 - - The appliance must be freely accessible from below (i.e. for accessing the lower liquid safety collector).
 - - No false floor is necessary below the cooktop with integrated downdraft ventilation system. The drawers and/or shelves in the floor unit must be removable. The backpanel of the floor unit can be kept - only a cut-out for the air outlet is needed (position and size can be taken from the installation instructions).
 - An installation with unducted recirculation requires a vertical aperture of min. 25mm behind the backpanel of the furniture. Suggested for ideal performance are 50mm.
 - The minimum worktop thickness is 16 mm for top mounted and flush installed appliances with the standard installation system. Installation in even thinner worktops is also possible with the spare part: content 626792.
 - - The overall appliance weight is 26kg - the bearing capacity and stability, in the case of very thin worktops in particular, must be supported using suitable substructures. The overall appliance weight and the worktop manufacturer's structural integrity specifications are to be taken into account.
 - - For partly ducted and unducted recirculation extraction installations, a return-flow aperture of $\geq 400\text{cm}^2$ is to be respected in the plinth area. The aperture can be realized via outlet grids, lamella grids or subtly shortened plinths depending on the assortment of the kitchen furniture manufacturer.
 - - The air outlet on the backside of the appliance can directly be accessed with a male flat duct element (DN 150).
 - - The pressuredrop resistant blower allows longer and more complex ductings up to 8m with three 90° bows while keeping sufficient performance.
 - - When installing a ventilation hood with ducted extraction and a chimney-vented fireplace, the power supply line of the appliance needs a suitable safety switch. This is not required for configurations in recirculated extraction.
 - - In ducted extraction configuration a one-way flap (or backflow trap) with a maximum opening pressure of 65Pa should be installed.

N 90, Induction hob with integrated ventilation system, 80 cm
T58TL6EN2

Dimensioned drawings

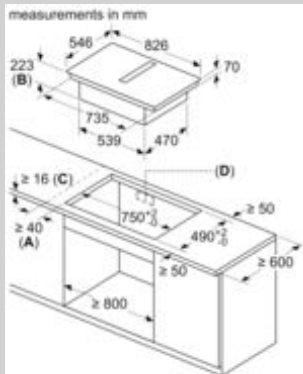

A: Minimum distance from the hob cut-out to the wall
B: Recessing depth
C: The worktop into which the hob is installed must withstand loads of approx. 60kg; suitable substructures must be used if required.

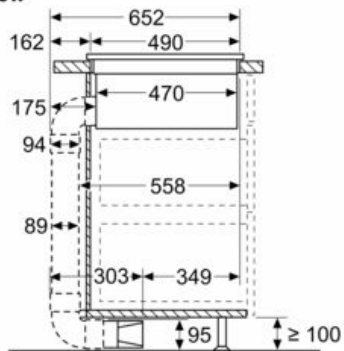
 Measurements in mm
Side view

With 90° elbow connectors from third-party suppliers

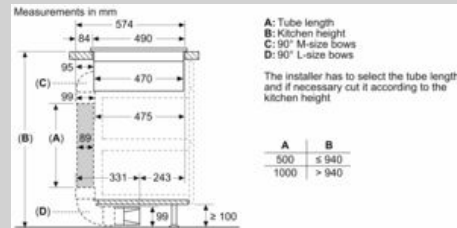

A: Tube length
B: Kitchen height
C: 90° M-size bows
D: 90° L-size bows
 The installer has to select the tube length and if necessary cut it according to the kitchen height

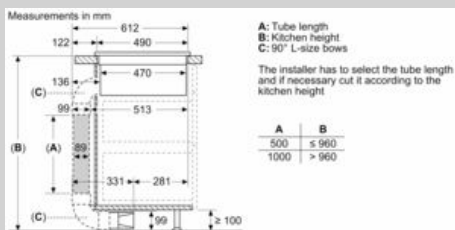
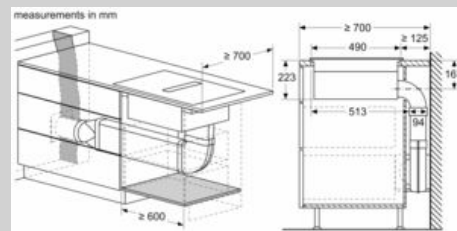

A: Tube length
B: Kitchen height
C: 90° L-size bows
 The installer has to select the tube length and if necessary cut it according to the kitchen height

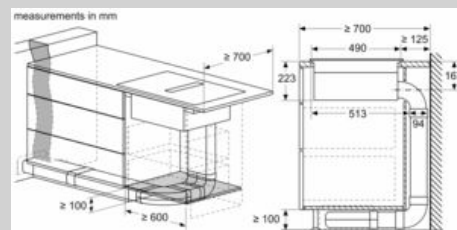

N 90, Induction hob with integrated ventilation
system, 80 cm
T58TL6EN2

Dimensioned drawings

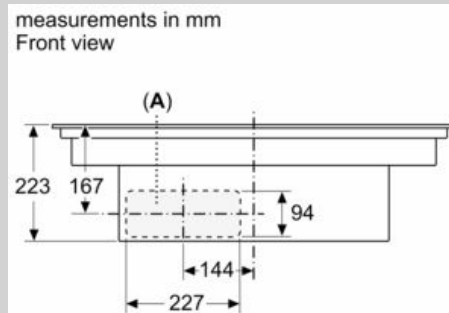
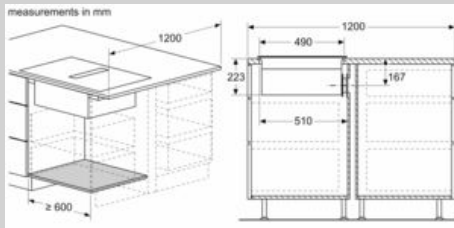

A: Connected directly at the rear

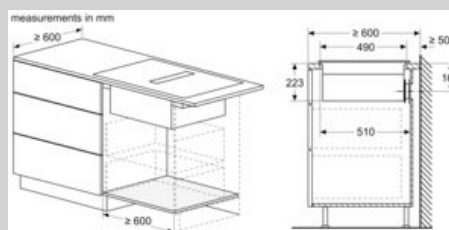
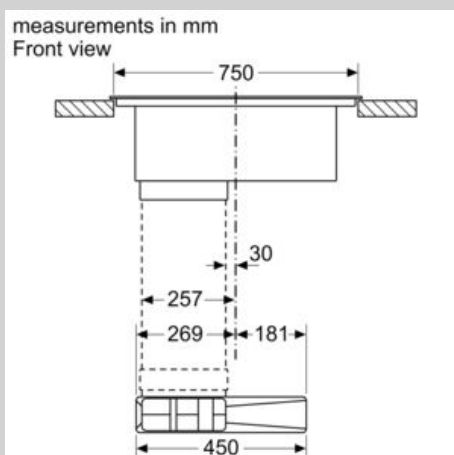
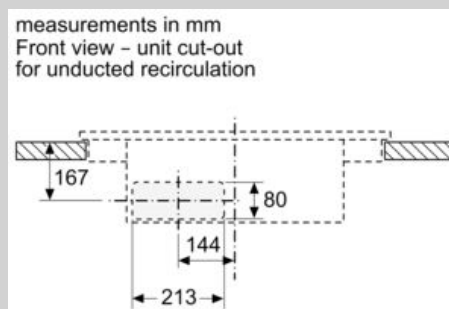
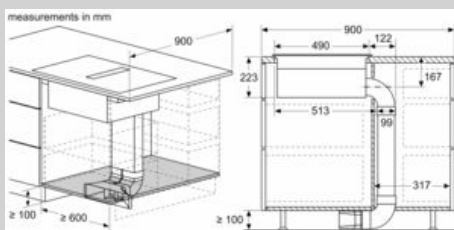

*N 90, Induction hob with integrated ventilation
system, 80 cm
T58TL6EN2*

Dimensioned drawings

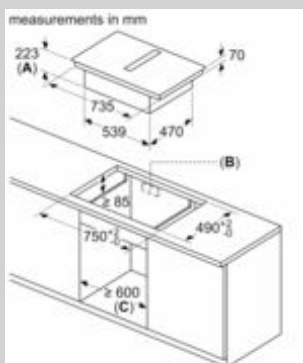
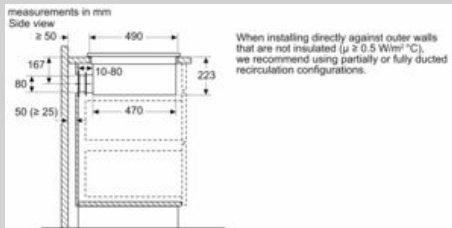

- A:** Recess depth
B: Cut-out in back panel required for pipework. Exact size and position can be taken from specific drawing.
C: All 80 cm width class models can be installed in 60 cm wide furniture by adjusting the side panels.

